

## Standard Equipment/Optional Equipment

### Standard Equipment

#### General:

- Overall width (reach legs) 1270 mm
- Linde Load Control for lift/lower, reach, tilt and side shift
- Linde twin accelerator pedals
- Comprehensive digital instrument display
- Maintenance-free AC 6,5 kW drive & 14 kW lift motors
- Linde 180° electric steering
- Linde Digital Control System (LDC) for smooth, precise electronic control of all traction and hydraulic functions
- Polyurethane drive and load wheels tyres
- New Standard Features:**
- Resiliently mounted operator's compartment
- Fully adjustable seat with manual weight adjustment
- Integral, adjustable control console
- Generous storage compartments
- Lift height indicator above free lift zone (STD and TX)
- Key switch
- Mast:**
- Torsion-resistant clear view tilt standard or triplex mast
- Fork length 1150 mm

#### Safety:

- Monitoring system stops truck in the event of traction, steering or lift failure
- Seat-actuated traction interlock
- Linde Curve Assist
- Four independent braking systems (Regenerative and counter current braking, holding brake control with automatic parking brake and all-wheel brake system)
- Automatic slowdown at end of reach travel and at max. lift
- Lift height related travel speed reduction
- Emergency isolator
- Battery lock with creep speed interlock
- Electrical and hydraulic overload protection
- Protective polycarbonate screen between console and mast
- Electric horn

### Optional Equipment

- Torsion-resistant clear view tilt standard or triplex mast with lift heights between 2930 mm and 7710 mm
- Side shift centering\*
- Alternative fork lengths
- Fork extensions
- Load backrest
- Single axis joysticks for each hydraulic function
- Single accelerator pedal, automotive layout with left foot interlock
- 360° steering (single accelerator pedal only)
- Reverse steering
- PVC covered seat
- High Vision armoured glass roof
- Draught protection door
- Protection frame
- Steel mesh profile or polycarbonate insert for overhead guard
- Profiled overhead guard for drive-in racking
- Side guidance wheels
- Load wheel protection
- Fan underneath overhead guard for driver comfort
- Radio Data Terminal bracket
- Option bar
- Interior light
- Auxiliary 12 V power socket

- LED working lamps
- Rotating/flashing beacon
- Blue Spot™ safety light
- LFM Linde Fleet management
- Audible traction alarm
- Additional hydraulic circuit for attachments\*
- Battery on rollers
- Battery roller stand
- Alternative colour schemes

- Other options available on request
- \* Availability to be advised



## Electric Reach Trucks Capacity 1000 - 1600 kg R 10 B, R 12 B, R 14 B, R 16 B

Series 1120

Linde Material Handling

Linde

### Safety

With four independent braking systems, fail-to-safe dual circuitry and an impressive range of operator protection features, a safe and efficient working environment is assured.

### Performance

Powerful AC traction and lift motors combined with the renowned Linde intelligent controller to deliver seamless, energy efficient performance for best productivity. Torsion-resistant clear view tilt standard or triplex masts ensure smooth, highly efficient storage and retrieval cycles.

### Comfort

A world first sees the operator's work station resiliently mounted to the base chassis isolating the operator from shocks and vibrations. An ergonomic, fully adjustable seat and integral control console housing the fingertip joystick hydraulic levers together with a compact steering wheel gives unsurpassed levels of operator comfort. The unique Linde electric steering system enables effortless operation and assured manoeuvring and travelling. In this superb, stress-free working environment, the operator is motivated and can fully focus on the task.

## Features

### Superb working environment

- Outstanding comfort and functionality from the unique, resiliently mounted work station with a comfort seat that is fully adjustable to the operator's personal preferences
- Integral, adjustable control console incorporating all operating controls
- Linde Load Control: precise, effortless fingertip control of all mast movements
- High Vision armoured glass overhead guard top panel available as an option

### Precision

- Confident, seamless manoeuvring with unique Linde twin accelerator pedal
- High precision load handling with Linde Load Control
- Highly responsive electric steering
- Digital instrument display for instant readout of truck status
- Integral, adjustable operator's control console



### Linde twin accelerator pedals

- Seamless and effortless forward/reverse selection provides outstanding traction control and places minimal demands on operator
- His left foot is safely protected within the chassis contours
- The operator is able to maintain high levels of efficiency and productivity



### Manoeuvrability

- A short wheelbase with compact chassis dimensions and smooth, electric steering ensure easy, efficient manoeuvring and accurate straight line traction performance
- Excellent all-round visibility of the load and surrounding environment



### Linde clear view mast

- Torsion-resistant, clear view standard and triplex tilt masts
- Twin cylinder configuration for optimum visibility (STD-mast), plus center free lift cylinder on TX-mast
- Hydraulic hoses reeved through the mast to enhance visibility (above chains)

### Stability

- Chassis designed and built for maximum strength and durability
- Heavy-duty design and components enhance the inherent low centre of gravity for optimum stability and high residual capacities
- Linde Curve Assist for safe cornering

### Batteries

- Capacities to suit every application: 420 Ah to 620 Ah
- Rapid and simple battery change - either lift-out or battery on rollers



### Servicing

- Configurable 1120 B Linde Digital Control system (LDC) incorporates diagnostic technology
- Easy service access
- Maintenance-free AC traction, lift and steer motors
- Up to 1000 operating hours between services

Linde Material Handling GmbH, Postfach 10 01 36, 63701 Aschaffenburg, Germany  
Phone +49.6021.99-0, Fax +49.6021.99-1570, www.linde-mh.com, info@linde-mh.com

Linde Material Handling

Linde

# Technical Data according to VDI 2198

		LINDE					
		R10B	R12B	R14B	R16B		
Characteristics	1.1	Manufacturer	LINDE	LINDE	LINDE	LINDE	
	1.2	Model designation	R10B	R12B	R14B	R16B	
	1.2a	Series	1120-00	1120-00	1120-00	1120-00	
	1.3	Power unit	Battery	Battery	Battery	Battery	
	1.4	Operation	Seat	Seat	Seat	Seat	
	1.5	Load capacity/Load	Q (t)	1.0	1.2	1.4	1.6
	1.6	Load centre	c (mm)	600 / 500	600 / 500	600 / 500	600 / 500
	1.8	Axle centre to fork face	x (mm)	326 <sup>1)</sup>	326 <sup>1)</sup>	360 <sup>1)</sup>	427 <sup>1)</sup>
	1.9	Wheelbase	y (mm)	1275	1275	1381	1453
Weights	2.1	Service weight	(kg)	2825 <sup>2)</sup>	2890 <sup>2)</sup>	3270 <sup>2)</sup>	3280 <sup>2)</sup>
	2.3	Axle load without load, front/rear	(kg)	1750 / 1075	1770 / 1120	1950 / 1320	2015 / 1265
	2.4	Axle load, fork outreached, with load, front/rear	(kg)	725 / 3100	600 / 3490	580 / 4090	645 / 4235
	2.5	Axle load, fork retracted, with load, front/rear	(kg)	1535 / 2290	1512 / 2578	1707 / 2963	1824 / 3056
	3.1	Tyres rubber, SE, pneumatic, polyurethane		Polyurethane	Polyurethane	Polyurethane	Polyurethane
Wheels/Tyres	3.2	Tyre size, front		Ø 360 x 130	Ø 360 x 130	Ø 360 x 130	Ø 360 x 130
	3.3	Tyre size, rear		Ø 285 x 100	Ø 285 x 100	Ø 285 x 100	Ø 285 x 100
	3.5	Wheels, number front/rear (x = driven)		1x / 2	1x / 2	1x / 2	1x / 2
	3.6	Track width, front	b10 (mm)	0	0	0	0
	3.7	Track width, rear	b11 (mm)	1167	1167	1167	1167
Dimensions	4.1	Mast/fork carriage tilt, forward/backward	a/b (°)	2.0 / 2.0	2.0 / 2.0	2.0 / 2.0	2.0 / 2.0
	4.2	Height of mast, lowered	h1 (mm)	2524	3024	2524	2524
	4.3	Free lift	h2 (mm)	150	150	1857	1857
	4.4	Lift	h3 (mm)	3830	4830	5710	5710
	4.5	Height of mast, extended	h4 (mm)	4451	5451	6379	6379
	4.7	Height of overhead guard (cabin)	h6 (mm)	2110	2110	2110	2110
	4.8	Height of seat/stand on platform	h7 (mm)	910 - 1040	910 - 1040	910 - 1040	910 - 1040
	4.19	Overall length	l1 (mm)	2318 <sup>3)</sup>	2318 <sup>3)</sup>	2390 <sup>3)</sup>	2395 <sup>3)</sup>
	4.20	Length to fork face	l2 (mm)	1168	1168	1240	1245
	4.21	Overall width	b1/b2 (mm)	1270	1270	1270	1270
	4.22	Fork dimensions	s/e/l (mm)	40 x 80 x 1150	40 x 80 x 1150	40 x 80 x 1150	45 x 100 x 1150
	4.23	Fork carriage to ISO 2328, class/type A, B		2A	2A	2A	2A
	4.24	Width of fork carriage	b3 (mm)	880	880	880	880
	4.25	Fork spread, min/max	b5 (mm)	296 / 829	296 / 829	296 / 829	296 / 829
	4.26	Width between reach legs	b4 (mm)	920	920	920	920
	4.28	Reach travel	l4 (mm)	515	515	548	612
	4.31	Ground clearance, below mast	m1 (mm)	90	90	90	90
4.32	Ground clearance, centre of wheelbase	m2 (mm)	70	70	70	70	
4.33	Aisle width with pallet 1000 x 1200 across forks	Ast (mm)	2644 <sup>3) 2)</sup>	2644 <sup>3) 2)</sup>	2717 <sup>3) 2)</sup>	2740 <sup>3) 2)</sup>	
4.34	Aisle width with pallet 800 x 1200 along forks	Ast (mm)	2703 <sup>3) 2)</sup>	2703 <sup>3) 2)</sup>	2770 <sup>3) 2)</sup>	2780 <sup>3) 2)</sup>	
4.35	Turning radius	Wa (mm)	1542 <sup>4)</sup>	1542 <sup>4)</sup>	1640 <sup>4)</sup>	1710 <sup>4)</sup>	
4.37	Length of chassis	l7 (mm)	1639	1639	1737	1817	
Performance	5.1	Travel speed, with/without load	(km/h)	11 / 11 <sup>5) 6)</sup>	11 / 11 <sup>5) 6)</sup>	11 / 11 <sup>5) 6)</sup>	11 / 11 <sup>5) 6)</sup>
	5.2	Lifting speed, with/without load	(m/s)	0.51 / 0.57	0.45 / 0.57	0.43 / 0.57	0.4 / 0.57
	5.3	Lowering speed, with/without load	(m/s)	0.55 / 0.55	0.55 / 0.55	0.55 / 0.55	0.55 / 0.55
	5.4	Reach speed, with/without load	(m/s)	0.16	0.16	0.16	0.16
	5.8	Maximum climbing ability, with/without load	(%)	10.0 / 10.0	10.0 / 10.0	10.0 / 10.0	10.0 / 10.0
	5.9	Acceleration time, with/without load	(s)	-	-	-	-
5.10	Service brake		hydr./mech.	hydr./mech.	hydr./mech.	hydr./mech.	
Drive	6.1	Drive motor, 60 minute rating	(kW)	6.5	6.5	6.5	6.5
	6.2	Lift motor, rating at S3 15%	(kW)	14	14	14	14
	6.3	Battery according to DIN 43531/35/36 A,B,C,no		43 531 / C	43 531 / C	43 531 / C	43 531 / C
	6.4	Battery voltage/rated capacity (5h)	(V/Ah)	48 / 420/465 <sup>2)</sup>	48 / 420/465 <sup>2)</sup>	48 / 420/465 <sup>2)</sup>	48 / 420/465 <sup>2)</sup>
	6.5	Battery weight (± 5%)	(kg)	750	750	750	750
	6.6	Power consumption according to VDI cycle	(kWh/h)	upon request	upon request	upon request	upon request
Others	8.2	Operating pressure for attachments	(bar)	-	-	-	-
	8.3	Oil flow for attachments	(l/min)	-	-	-	-
	8.4	Noise level at operator's ear	(dB(A))	64	64	64	64

1) - 30 mm with integrated side shifter  
 2) Alternative batteries may alter l1, Ast and service weight.  
 3) Including a 200 mm (min.) operating aisle clearance.

4) fn296 / 829  
 5) forward; backward  
 6) Depending on performance setting

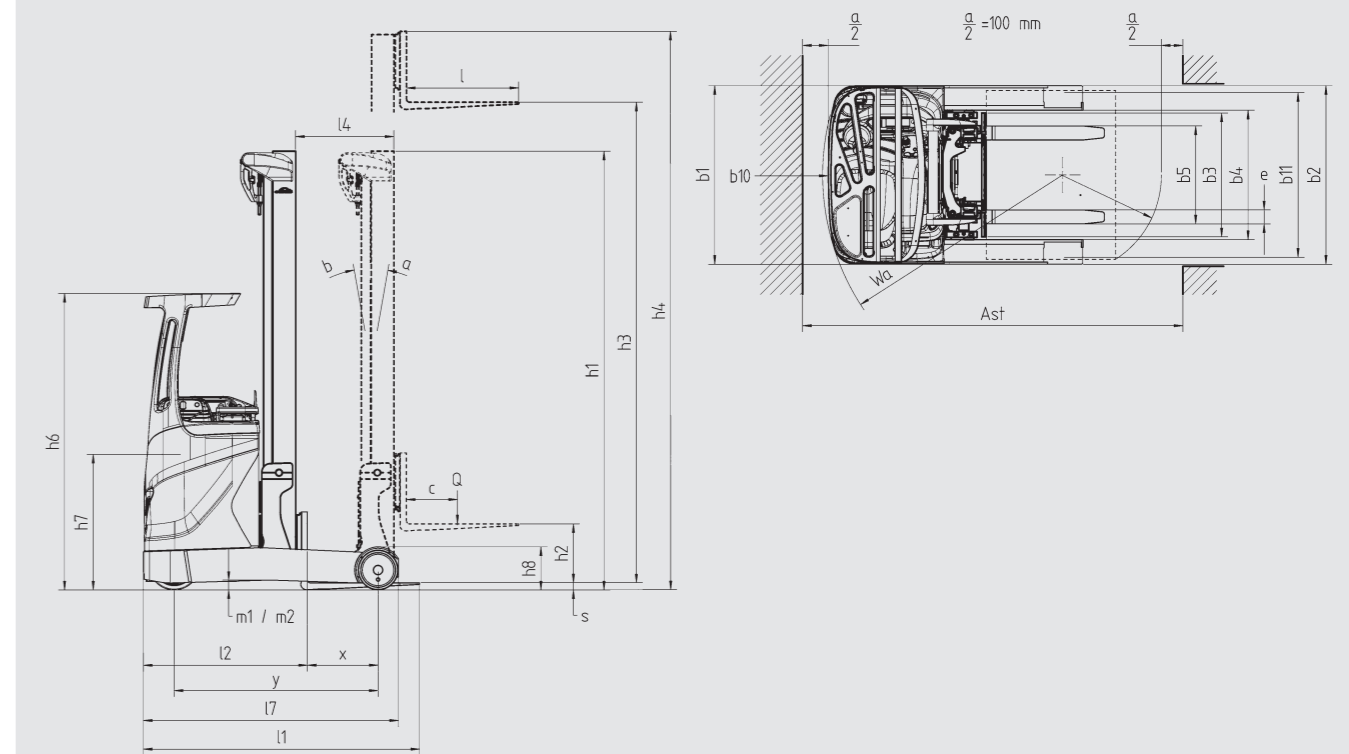

Clear view tilt standard mast															
R 10 B, R 12 B, R 14 B, R 16 B															
Lift	<b>h3</b>	3030	3330	3530	3730	3930	4130	4330	4530	4730	4930	5130	5330	5530	5630
Free lift	<b>h2</b>	150	150	150	150	150	150	150	150	150	150	150	150	150	150
Height of mast, lowered	<b>h1</b>	2124	2274	2374	2474	2574	2674	2774	2874	2974	3074	3174	3274	3374	3424
Height of mast, extended	<b>h4</b>	3690	3990	4190	4390	4590	4790	4990	5190	5390	5590	5790	5990	6190	6290

Clear view tilt triplex mast															
R 10 B, R 12 B, R 14 B, R 16 B															
Lift	<b>h3</b>	4610	4760	5210	5410	5710	5860	6010	6210	6510	6660	6960	7260	7560	7710
Free lift	<b>h2</b>	1457	1507	1657	1757	1857	1907	1957	2057	2157	2207	2307	2407	2507	2557
Height of mast, lowered	<b>h1</b>	2124	2174	2324	2424	2524	2574	2624	2724	2824	2874	2974	3074	3174	3224
Height of mast, extended	<b>h4</b>	5275	5425	5875	6075	6375	6525	6675	6875	7175	7325	7625	7925	8225	8375

Alternative lift heights are available on request.  
 Lift height = h3 + s