



Electric Series Scissor Lifts

**0608E(2132E)/0808E(2732E)/0612E(2146E)
0812E(2746E)/1012E(3346E)/1212E(4047E)
1412E(4647E)/1412E Plus/1414E(4655E)**
Complies with ISO/CE/ANSI/AS/CU-TR/KCS standards

Product Highlights

Efficient and environmentally friendly

- Higher work efficiency
- Environmental protection, zero emissions

Reduced maintenance costs

- Exclusive open chassis design reduces daily maintenance costs
- Rapid, convenient transportation with two-way forklift slot
- Lower cost of ownership with highly versatile parts and components

More reliable performance

- New wide scissor design, for a more stable working-at-height experience
- Bumper rail and indented sliding groove designed for anti-scratch

Standard features		
■ Maintenance-free battery	■ Automatic braking system	■ Full-stroke operation
■ Proportional control	■ Emergency lowering system	■ Forklift pocket and lifting eyes
■ Bumper rail	■ Emergency stop at both platform and ground controls	■ Electrophoresic paint technology
■ 4x2 drive	■ Fault diagnosis system	■ Foldable guardrail
■ Non-marking tyres	■ Tilt protection	■ Overload sensing system
■ Integrated hand shield	■ Automatic pothole guard	
Optional features		
■ Overhead anti-collision device	■ Headlight	■ RCBO
■ AC power to platform		

Model	0608E (2132E)	0808E (2732E)	0612E (2146E)
Dimensions			
Max Working Height	8.3m(27'3")	10.1m(33'2")	8.3m(27'3")
A Max Platform Height	6.3m(20'8")	8.1m(26'7")	6.3m(20'8")
B Max Horizontal Extension	0.9m(3')	0.9m(3')	0.9m(3')
C Length-Stowed	2.46m(8')	2.46m(8')	2.45m(8')
D Width-Stowed	0.83m(2'9")	0.83m(2'9")	1.17m(3'10")
Height-stowed	Rail Folded	1.84m(6')	1.96m(6'5")
	E Rail Unfolded	2.24m(7'4")	2.36m(7'9")
F Wheelbase	1.88m(6'2")	1.88m(6'2")	1.88m(6'2")
Ground Clearance (Pothole Guard Stowed)	0.1m(4")	0.1m(4")	0.1m(4")
Ground Clearance (Pothole Guard Deployed)	25mm(0.98")	25mm(0.98")	25mm(0.98")
Platform Dimensions(L×W×H)	2.30m×0.8m×1.1m (7'7"×2'8"×3'7")	2.30m×0.8m×1.1m (7'7"×2'8"×3'7")	2.30m×1.15m×1.1m (7'7"×3'9"×3'7")
Performance			
Platform Allowable Occupants (Indoors/Outdoors)	2 persons/1 person	2 persons/-	2 persons
Platform Capacity	380kg(838lbs)	250kg(551lbs)	550kg(1213lbs)
Drive Speed-Stowed	4km/h(2.5mph)	4km/h(2.5mph)	4km/h(2.5mph)
Drive Speed-Raised	0.8km/h(0.5mph)	0.8km/h(0.5mph)	0.8km/h(0.5mph)
Elevation Time(Unloaded)	25s-30s	30s-35s	33s-38s
Descent Time(Unloaded)	30s-35s	34s-39s	30s-35s
Gradeability	25%	25%	25%
Turning Radius(Inside/Outside)	0/2.1m	0/2.1m	0/2.35m
Tilt Rating(Front to Back/Side to Side)	3°/1.5°	3°/1.5°	3°/1.5°
Tire Spec/Type	380×125mm (15×5 in)/solid	380×125mm (15×5 in)/solid	380×125mm (15×5 in)/solid
Power			
Batteries	6V×4/225Ah	6V×4/225Ah	6V×4/225Ah
Power Source	24V DC	24V DC	24V DC
Drive Mode	Motor, front-wheel	Motor, front-wheel	Motor, front-wheel
Charger Input	100-240V AC	100-240V AC	100-240V AC
Charger Output	30A	30A	30A
Hydraulic System Capacity	14L(3.1gal)	14L(3.1gal)	19L(4.2gal)
Weight			
Weight(Indoor)	2,090kg(4,608 lbs)	2,265kg(4,994lbs)	2,360kg(5,204lbs)
Standards Compliance	ISO/CE/ANSI/CSA/AS/CU-TR/KCS		

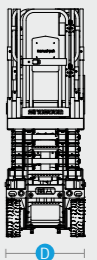
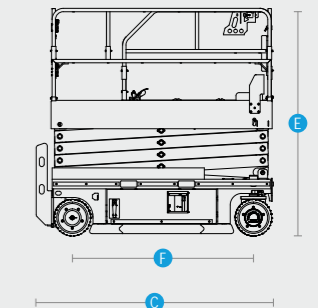
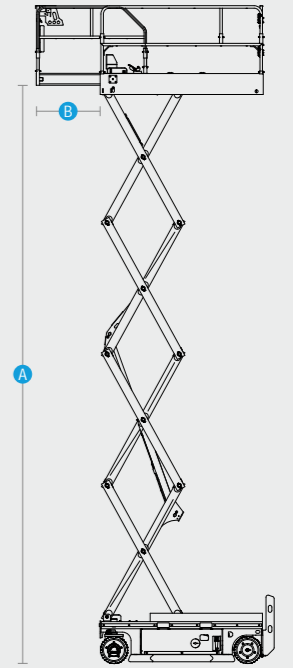



Model	0812E (2746E)	1012E (3346E)	1212E (4047E)
Dimensions			
Max Working Height	10.1m(33'2")	12m(39'4.5")	13.9m(45'7")
A Max Platform Height	8.1m(26'7")	10m(32'10")	11.9m(39')
B Max Horizontal Extension	0.9m(3')	0.9m(3')	0.9m(3')
C Length-Stowed	2.45m(8')	2.45m(8')	2.45m(8')
D Width-Stowed	1.17m(3'10")	1.17m(3'10")	1.17m(3'10")
Height - stowed	Rail Folded	1.73m(5'8")	1.98m(6'1")
	E Rail Unfolded	2.36m(7'9")	2.6m(8'2")
F Wheelbase	1.88m(6'2")	1.88m(6'2")	1.88m(6'2")
Ground Clearance (Pothole Guard Stowed)	0.1m(4")	0.1m(4")	0.1m(4")
Ground Clearance (Pothole Guard Deployed)	25mm(0.98")	25mm(0.98")	25mm(0.98")
Platform Dimensions(L×W×H)	2.30m×1.15m×1.1m (7'6.5"×3'9"×3'7")	2.30m×1.15m×1.1m (7'6.5"×3'9"×3'7")	2.30m×1.15m×1.1m (7'6.5"×3'9"×3'7")
Performance			
Platform Allowable Occupants (Indoors/Outdoors)	2persons/-	2persons/1person	Indoors: 2persons Outdoors: 1person (outside working height 9m)
Platform Capacity	450kg(992lbs)	320kg(705.6lbs)	320kg(705.6lbs)
Drive Speed-Stowed	4km/h(2.5mph)	4km/h(2.5mph)	4km/h(2.5mph)
Drive Speed-Raised	0.8km/h(0.5mph)	0.8km/h(0.5mph)	0.8km/h(0.5mph)
Elevation Time(Unloaded)	33s~38s	53s~58s	63s~68s
Descent Time(Unloaded)	35s~40s	40s~45s	44s~49s
Gradeability	25%	25%	25%
Turning Radius(Inside/Outside)	0/2.35m(0/7'9")	0/2.35m(0/7'9")	0/2.35m(0/7'9")
Tilt Rating (Front to Back/Side to Side)	3°/1.5°	3°/1.5°	3°/1.5°
Tire Spec/Type	380×125mm (15×5 in)/solid	380×125mm (15×5 in)/solid	380×125mm (15×5 in)/solid
Power			
Batteries	6V×4/240Ah	6V×4/240Ah	6V×4/300Ah
Power Source	24V DC	24V DC	24V DC
Drive Mode	Motor, front-wheel	Motor, front-wheel	Motor, front-wheel
Charger Input	100~240V AC	100~240V AC	100~240V AC
Charger Output	30A	30A	30A
Hydraulic System Capacity	19L(4.2gal)	34L(7.5gal)	34L(7.5gal)
Weight			
Weight(Indoor & Outdoor)	2,600kg(5,733lbs)	2,700kg(5,953.5lbs)	3,075kg(6,780lbs)
Weight(Indoor Only)	-	2,530kg(5,579lbs)	2,965kg(6,538lbs)
Standards Compliance	ISO/CE/ANSI/CSA/AS/CU-TR/KCS		

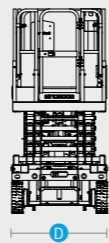
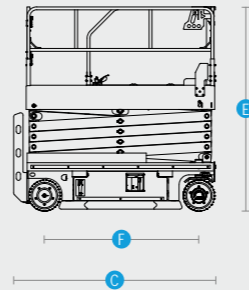
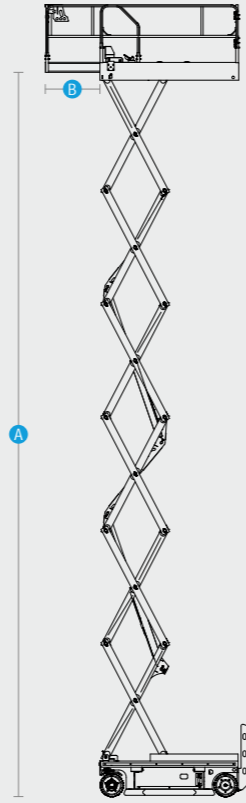

Model	1412E(4647E)	1412E Plus	1414E(4655E)
Dimensions			
Max Working Height	15.8m(51'10")	15.8m(51'10")	15.8m(51'10")
A Max Platform Height	13.8m(45'3")	13.8m(45'3")	13.8m(45'3")
B Max Horizontal Extension	0.9m(3')	0.9m(3')	0.9m(3')
C Length-Stowed	2.78m(9')	2.78m(9')	2.78m(9')
D Width-Stowed	1.27m(4'2")	1.27m(4'2")	1.41m(4'7")
Height - stowed	Rail Folded	1.96m(6'5")	1.96m(6'5")
	E Rail Unfolded	2.6m(8'6")	2.6m(8'6")
F Wheelbase	2.22m(7'3")	2.22m(7'3")	2.22m(7'3")
Ground Clearance(Pothole Guard Stowed)	0.1m(4")	0.1m(4")	0.1m(4")
Ground Clearance(Pothole Guard Deployed)	25mm(0.98")	25mm(0.98")	25mm(0.98")
Platform Dimensions(L×W×H)	2.64m×1.15m×1.1m (8'8"×3'9"×3'7")	2.64m×1.15m×1.1m (8'8"×3'9"×3'7")	2.64m×1.15m×1.1m (8'8"×3'9"×3'7")
Performance			
Platform Allowable Occupants (Indoors/Outdoors)	2 persons/-	2 persons/-	2 persons/1 person
Platform Capacity	227kg(500lbs)	350kg(772lbs)	227kg(500lbs)
Drive Speed-Stowed	4km/h(2.5mph)	4km/h(2.5mph)	4km/h(2.5mph)
Drive Speed-Raised	0.8km/h(0.5mph)	0.8km/h(0.5mph)	0~0.8km/h(0.5mph)
Elevation Time(Unloaded)	75s~85s	75s~85s	75s~85s
Descent Time(Unloaded)	55s~63s	55s~63s	55s~63s
Gradeability	25%	25%	25%
Turning Radius(Inside/Outside)	0/2.64m(0/8'8")	0/2.64m(0/8'8")	0/2.64m(0/8'8")
Tilt Rating(Front to Back/Side to Side)	3°/1.5°	3°/1.5°	3°/1.5°
Tire Spec/Type	380×125mm(15×5")/solid	380×125mm(15×5")/solid	380×125mm(15×5")/solid
Power			
Batteries	12V×4/300Ah	12V×4/300Ah	12V×4/300Ah
Power Source	24V DC	24V DC	24V DC
Drive Mode	Motor, front-wheel	Motor, front-wheel	Motor, front-wheel
Charger Input	100~240V AC	100~240V AC	100~240V AC
Charger Output	30A	30A	30A
Hydraulic System Capacity	41L(9gal)	41L(9gal)	41L(9gal)
Weight			
Weight(Indoor Only)	3,375kg(7,442lbs)	3,375kg(7,442lbs)	3,430kg(7,563lbs)
Standards Compliance	ISO/CE/ANSI/CSA/AS/CU-TR/KCS		

